

Specifications

MODELS	GS™-2668 DC		GS™-3268 DC	
MEASUREMENTS	US	Metric	US	Metric
Working height maximum*	32 ft	9.92 m	38 ft	11.75 m
A Platform height	26 ft	7.92 m	32 ft	9.75 m
B Platform height - stowed	3 ft 10.75 in	1.19 m	4 ft 3.75 in	1.31 m
C Platform length - outside	8 ft 3 in	2.51 m	8 ft 3 in	2.51 m
extended	13 ft	3.96 m	13 ft	3.96 m
Slide-out platform extension deck	5 ft	1.52 m	5 ft	1.52 m
D Platform width - outside	5 ft 1 in	1.55 m	5 ft 1 in	1.55 m
Toeboard height	6 in	.15 m	6 in	.15 m
E Height - stowed	7 ft 5.5 in	2.32 m	8 ft 3 in	2.45 m
rails lowered	5 ft 7 in	1.70 m	6 ft	1.83 m
F Length - stowed	8 ft 9 in	2.67 m	8 ft 9 in	2.67 m
platform extended	13 ft 9 in	4.19 m	13 ft 9 in	4.19 m
G Width	5 ft 8 in	1.73 m	5 ft 8 in	1.73 m
H Wheelbase	6 ft 1 in	1.85 m	6 ft 1 in	1.85 m
I Ground clearance - center	8 in	.20 m	8 in	.20 m

PRODUCTIVITY

Maximum platform capacity**	4	4	4	4
Lift capacity	1,250 lbs	567 kg	1,000 lbs	454 kg
Extension deck capacity	300 lbs	136 kg	300 lbs	136 kg
Drive speed - stowed	3.0 mph	4.8 km/h	3.0 mph	4.8 km/h
Drive speed - raised	0.5 mph	0.8 km/h	0.5 mph	0.8 km/h
Gradeability - stowed***	30%		25%	
Turning radius - inside	5 ft	1.52 m	5 ft	1.52 m
Turning radius - outside	12 ft 1 in	3.68 m	12 ft 1 in	3.68 m
Raise/lower speed	30/35 sec		40/37 sec	
Controls	proportional		proportional	
Drive	dual rear wheel		dual rear wheel	
Multiple disc brakes	dual rear wheel		dual rear wheel	
Tires - foam-filled low profile turf	12.5 x 22 in	32 x 56 cm	12.5 x 22 in	32 x 56 cm

POWER

Power source	48 V DC (eight 225 Ah batteries)	48 V DC (eight 225 Ah batteries)
Hydraulic system capacity	9.5 gal	36 L

WEIGHT****

	6,657 lbs	3,020 kg	7,868 lbs	3,567 kg
--	-----------	----------	-----------	----------

STANDARDS COMPLIANCE

ANSI A92.6, CSA B354.2, CE Compliance, AS 1418.10

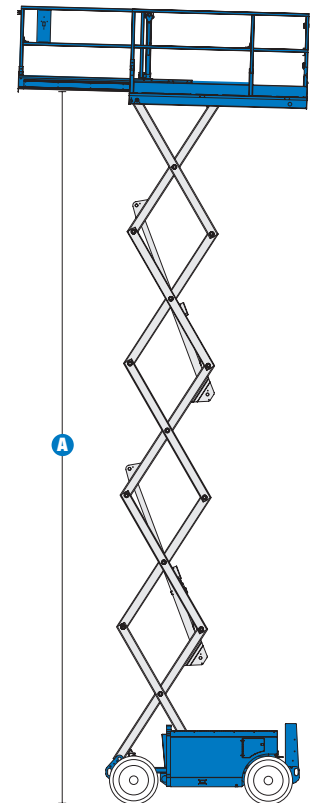
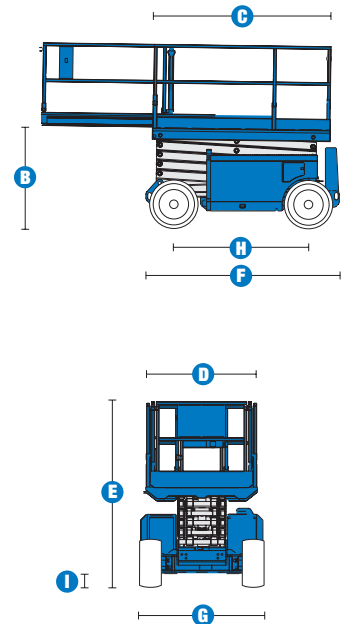

* The metric equivalent of working height adds 2 m to platform height. U.S. adds 6 ft to platform height.

** CE/AUS markets: GS-3268 limited to 2 person platform occupancy when used outdoors.

*** Gradeability applies to driving on slopes. See operator's manual for details regarding slope ratings.

**** Weight varies depending on options and country standards.

Features

STANDARD FEATURES

MEASUREMENTS

GS™-2668DC

- 32 ft (9.92 m) working height
- Up to 1,250 lb (567 kg) lift capacity

GS™-3268DC

- 38 ft (11.75 m) working height
- Up to 1,000 lb (454 kg) lift capacity

PRODUCTIVITY

- 99 x 61 in (2.51 x 1.55 m) steel frame platform with replaceable aluminum deck
- 60 in (1.52 m) extension deck
- Folding guardrails
- Dual rear wheel drive
- 48 V charger
- Proportional lift and drive
- Platform control with battery charge indicator and diagnostic display
- AC power to platform
- Full height swing gate
- Diamond plate deck
- Lanyard attachment points
- Manual platform lowering valve
- Dual rear wheel disc brakes
- Manual brake release
- Foam-filled low profile turf tires
- Tilt level sensor with audible alarm
- Descent alarm
- Horn
- Hour meter

POWER

- 48 V DC (eight 6 V 225 Ah batteries)

OPTIONS & ACCESSORIES

PRODUCTIVITY

- Air line to platform
- Pipe cradle (pair)
- Solid non-marking tires
9 x 21.5 in (22 x 55 cm)
- Dual flashing beacons
- Motion alarm
- Platform work lights

POWER

- Power inverter (110V / 60 HZ)
- Power inverter (230V / 50 Hz)



Genie United States

18340 NE 76th Street
P.O. Box 97030
Redmond, Washington 98073-9730

Telephone **+1 (425) 881-1800**
Toll Free in USA/Canada **+1 (800)-536-1800**
Fax +1 (425) 883-3475

Genie Europe

Millennium House
Brunel Drive
Newark NG24 2DE
UK

Telephone **+44 (0)1476 584333**
Fax +44 (0)1476 584334

Email: infoeurope@genieind.com

Distributed By:

Effective Date: January, 2009. Product specifications and prices are subject to change without notice or obligation. The photographs and/or drawings in this document are for illustrative purposes only. Refer to the appropriate Operator's Manual for instructions on the proper use of this equipment. Failure to follow the appropriate Operator's Manual when using our equipment or to otherwise act irresponsibly may result in serious injury or death. The only warranty applicable to our equipment is the standard written warranty applicable to the particular product and sale and we make no other warranty, express or implied. Products and services listed may be trademarks, service marks or trade-names of Terex Corporation, Genie Industries, Inc. and/or their subsidiaries in the U.S.A. and many other countries and all rights are reserved. Terex is a Registered Trademark of Terex Corporation in the U.S.A. and many other countries. Genie is a Registered Trademark of Genie Industries, Inc. in the U.S.A. and many other countries. Genie is a Terex Company. © 2009 Terex Corporation.

GS68DC 3.5K 0109J. Part No. 109349

www.genieindustries.com